

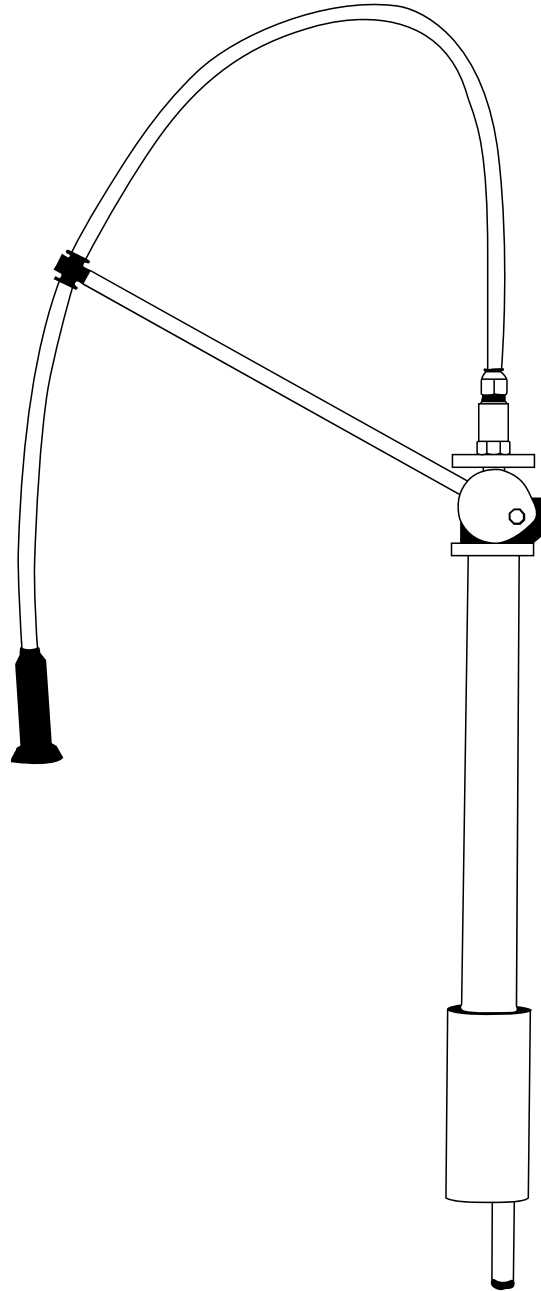

COMMERCIAL PRE-RINSE FAUCET INSTALLATION INSTRUCTIONS



INSTINCT



ISO9001:2015
CERTIFIED

©2015 Hayes Ivy Manufacturing, Inc. All Rights Reserved. Instinct is a registered trademark of Hayes Ivy Manufacturing, Inc.

Hayes Ivy Manufacturing, Inc.
Manufacturing Facility: 6273 Route 309, New Tripoli, PA 18066
Customer Service: (800) 523-9460
Fax: (610) 767-6473



www.himi-products.com

INSTALLATION

- 1** **FOR EXISTING INSTALLATIONS:**
Remove present unit.
Leave lower control valve in place.

FOR NEW INSTALLATIONS:
Install deck valve according to
manufacturer's instructions.

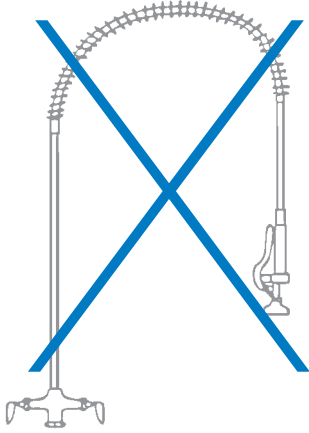

2

**APPLY THREAD
SEALANT TO BOTH
ENDS OF NIPPLE.**

Install nipple in control
valve and install main
assembly on other end
of nipple.

Then tighten from the
top coupling as shown.

APPLY TREAD SEALANT
AT TOP AND BOTTOM

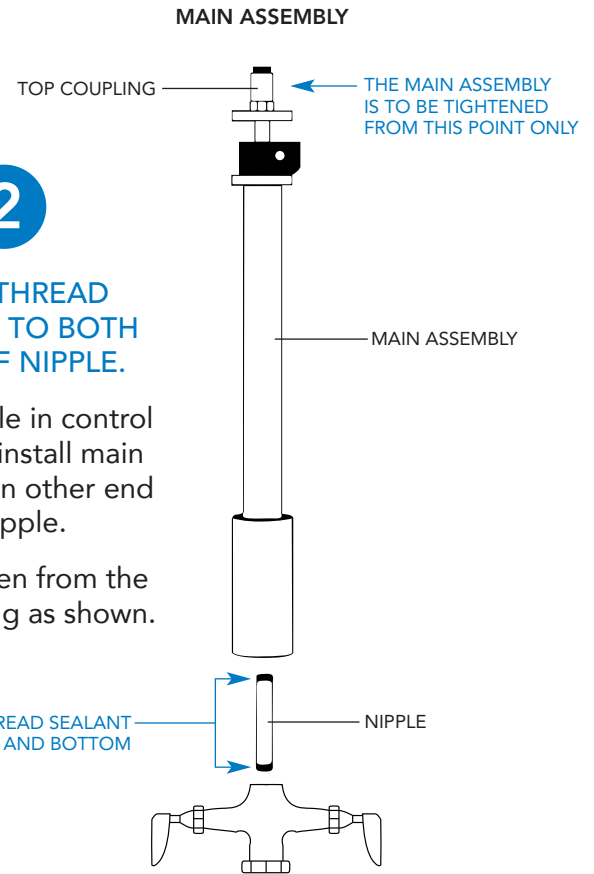

- 3** **INSERT STAINLESS BUSHING INTO BLOCK.**

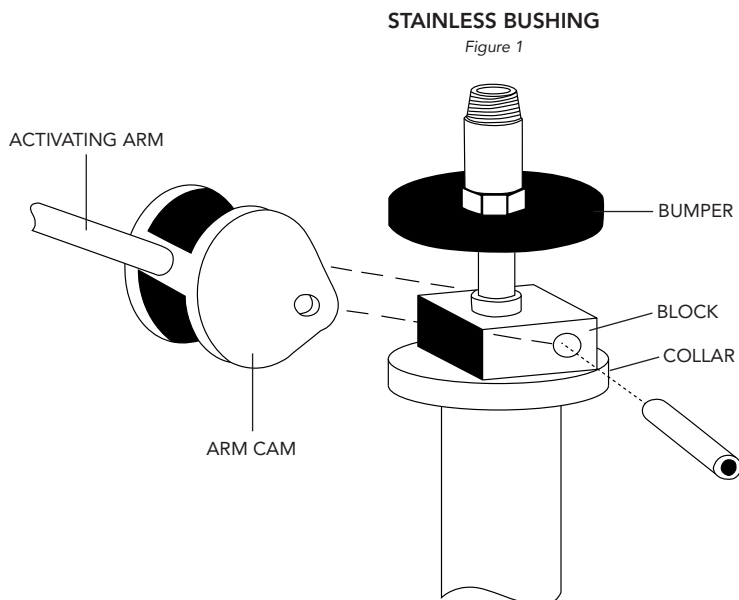

STAINLESS BUSHING

Figure 2

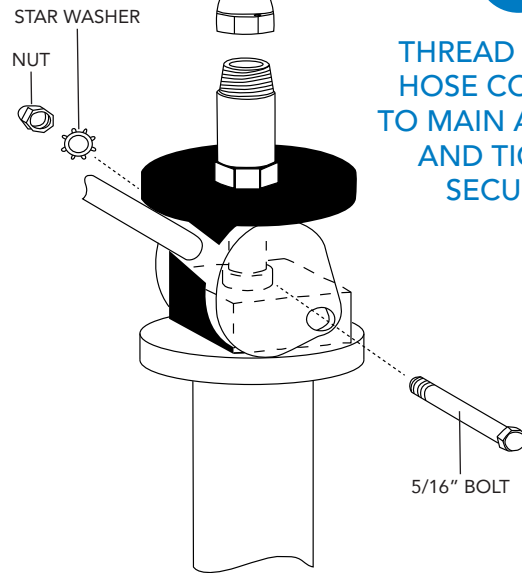

6

**THREAD FEMALE
HOSE COUPLING
TO MAIN ASSEMBLY
AND TIGHTEN
SECURELY.**

- 4** **INSERT ACTIVATING ARM CAM
BETWEEN BUMPER AND COLLAR.**

- 5** **INSTALL 5/16" BOLT THROUGH
ARM CAM AND BUSHING.
INSTALL WASHER AND TIGHTEN NUT.**

HOSE HEIGHT IS FIXED FOR NORMAL APPLICATIONS.

STANDARD HOSE LENGTH IS 54 INCHES.
IF ADDITIONAL SPRAY RANGE IS REQUIRED,
ORDER A 60 INCH HOSE.

7

CHECK FINAL ASSEMBLY
FOR LEAKS.

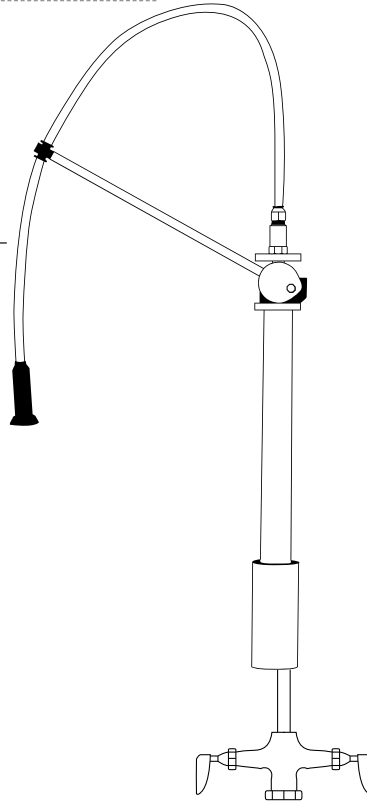

WALL BRACKET INSTALLATION

DESIGNED FOR USE WITH PRE-RINSE
UNITS WITHIN 12 INCHES OF WALL



NOTICE: WARRANTY VOID IF WALL BRACKET OR "Y" MOUNT IS NOT UTILIZED

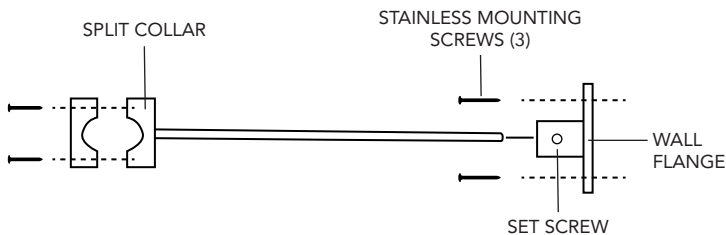

8

DETERMINE SUITABLE LOCATION
AND MOUNT WITH FLANGE.

9

DETERMINE ADEQUATE ROD LENGTH AND
CUT OFF EXCESS ROD. TIGHTEN SET SCREW
TO SECURE ROD IN WALL FLANGE.

10

INSTALL SPLIT COLLAR AROUND MAIN ASSEMBLY
AND SECURE WITH 2 SCREWS.

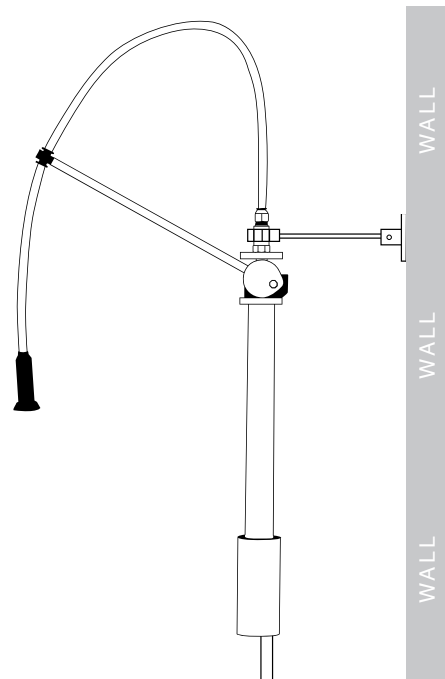

NOTE: FOR Y-MOUNT INSTALLATION, SEE BACK PAGE



Y-MOUNT INSTALLATION

DESIGNED FOR USE WITH PRE-RINSE
UNITS WHERE WALL MOUNT CANNOT BE USED

- 9** INSERT THE TWO ENDS OF THE STRUT A THROUGH THE TWO SPECIAL FITTINGS B ON THE STRUT BASE C. SLIDE THE BASE ONTO THE STRUT UNTIL APPROXIMATELY 1" OF THE STRUT EXTENDS BEYOND THE BOTTOM OF EACH FITTING.

ATTACH STRUT CLAMP D TO THE COLLAR JUST ABOVE THE UPSTOP RUBBER BUMPER E. **DO NOT FULLY TIGHTEN STRUT CLAMP SCREWS!**

NUT AND FERRULE
IN POSITION

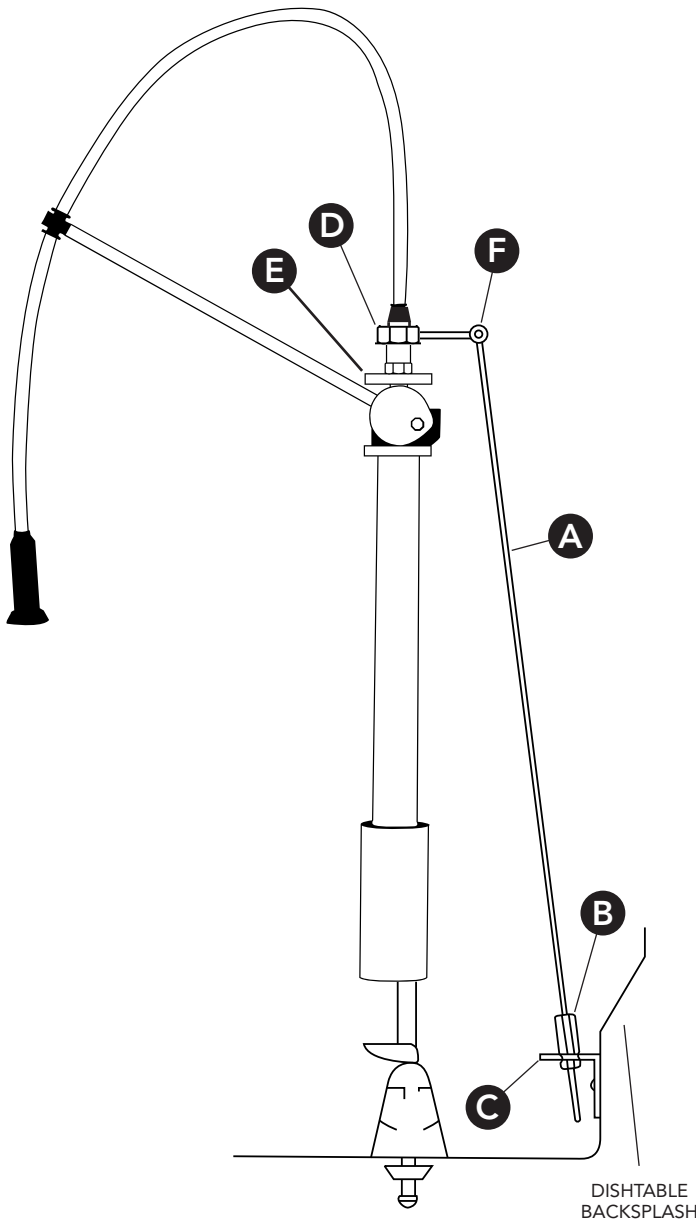
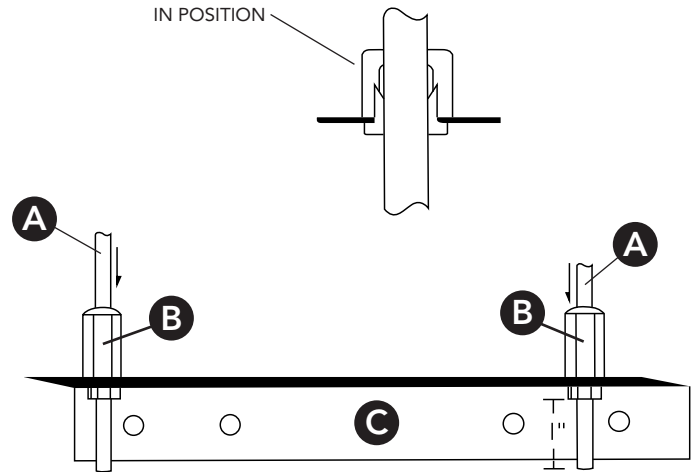

- 10** HOLD STRUT BASE C AGAINST DISHTABLE BACKSPASH, CENTER BEHIND FAUCET, AND MARK HOLE LOCATIONS FOR MOUNTING STRUT BASE C.
- 11** CENTER PUNCH AND DRILL HOLES IN BACKSPASH. IF DISHTABLE BACKSPASH IS ACCESSIBLE FROM THE REAR, DRILL TWO 1/4" HOLES FOR MOUNTING STRUT BASE C. MOUNT STRUT BASE WITH 1/4" HARDWARE. IF THE DISHTABLE BACKSPASH IS NOT ACCESSIBLE FROM BACK, DRILL TWO 11/64" HOLES. MOUNT STRUT BASE WITH SHEET METAL SCREWS SUPPLIED.
- 12** SECURELY TIGHTEN BOTH SPECIAL FITTINGS B ON THE STRUT BASE USING 1/2" AND 9/16" WRENCHES.
- 13** PUSH UP THE STRUT CLAMP D WHILE PRESSING BACK THE PRE-RINSE UNIT APPROXIMATELY 1". HOLD THE UNIT IN THIS POSITION AND TIGHTEN THE STRUT CLAMP SCREWS.
- 14** TIGHTEN STRUT CLAMP LOCKING SET SCREW F.